



FLYBAT

LiFePO₄

LITHIUM IRON PHOSPHATE BATTERY



PRODUCT IMAGE



Advantages of the FLYBAT lithium iron phosphate (LiFePO₄) batteries:

- 5 year manufacturer's warranty
- The safest technology, without the risk of fire or explosion
- Integrated BMS
- Long service life
- Steadily improving storage capacity
- 99 % efficient
- High stability even under extreme loads
- No memory effect - no need for full charge and discharge cycles
- High performance even under extreme conditions
- Deep and steady discharge and charging efficiency
- Small size and light weight

ELECTRICAL SPECIFICATIONS

Nominal Voltage	12.8 V	Resistance	30 mΩ
Nominal Capacity	200 Ah	Efficiency	99%
Capacity @ 25A	480 min	Self Discharge	<3% per Month
Energy	2560 Wh	Maximum Modules in Series/parallel	4/4

MECHANICAL SPECIFICATIONS

Dimensions	Length	520 mm
	Width	238 mm
	Height	218 mm
Weight		27,7 kg
Terminal Type		M8
Terminal Torque		9 - 11 N-m
Case Material		ABS
Enclosure Protection		IP56
Cell Type - Chemistry		Cylindrical - LiFePO ₄

TEMPERATURE SPECIFICATIONS

Discharge Temperature	-20 to 60 °C
Charge Temperature	0 to 55 °C
Storage Temperature	-20 to 60 °C
PCM High Temperature Cut-Off	80 °C

CHARGE SPECIFICATIONS

Recommended Charge Current	50 A
Maximum Charge Current	100 A
Recommended Charge Voltage	14.2 V - 14.6 V
PCM Charge Voltage Cut-Off	15.6 V
Reconnect Voltage	15.2 V
Balancing Voltage	14.4 V

DISCHARGE SPECIFICATIONS

Maximum Continuous Discharge Current	100 A
Peak Discharge Current	200 A (7.5 s ±2.5 s)
PCM Discharge Current Cut-Off	280 A (±50 A)
Recommended Low Voltage Disconnect	11 V
PCM Discharge Voltage Cut-Off	8 V
Reconnect Voltage	9.2 V
Short Circuit Protection	Yes



FLYBAT

LiFePO₄

LITHIUM IRON PHOSPHATE BATTERY



DIMENSIONAL SPECIFICATIONS

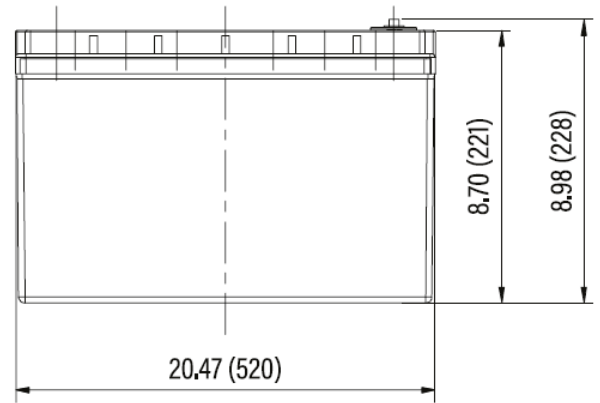
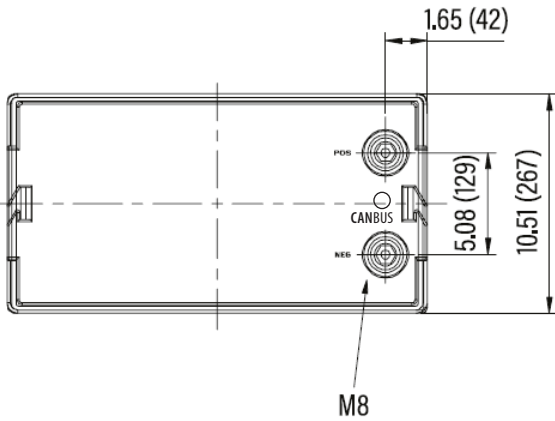

Charging Characteristics @0.5C 25°C

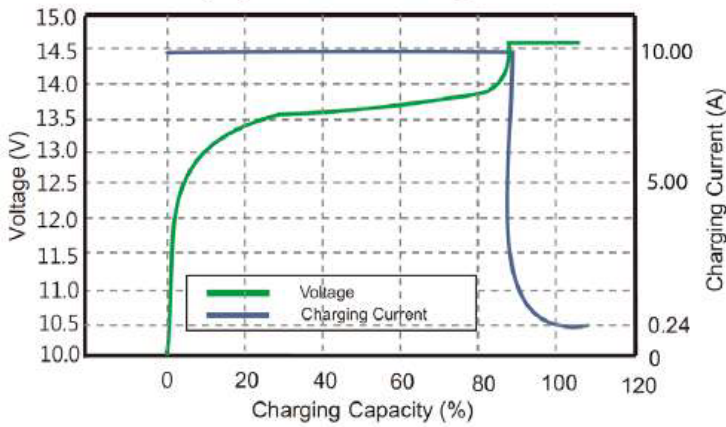

Different Rate Discharge Curve @25°C

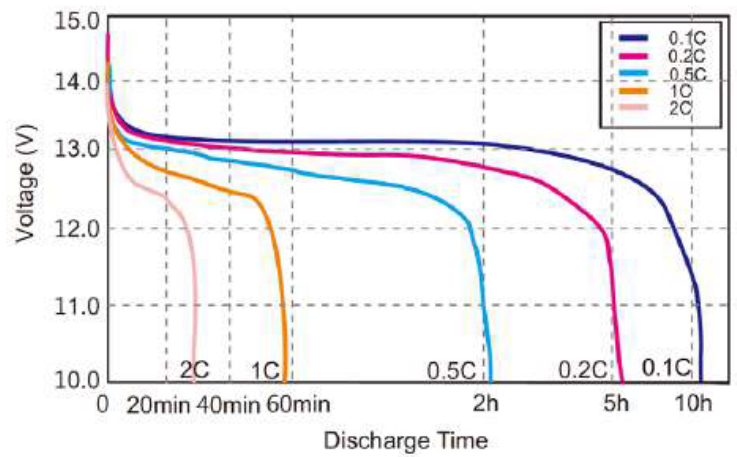

State of Charge Curve @0.5C 25°C

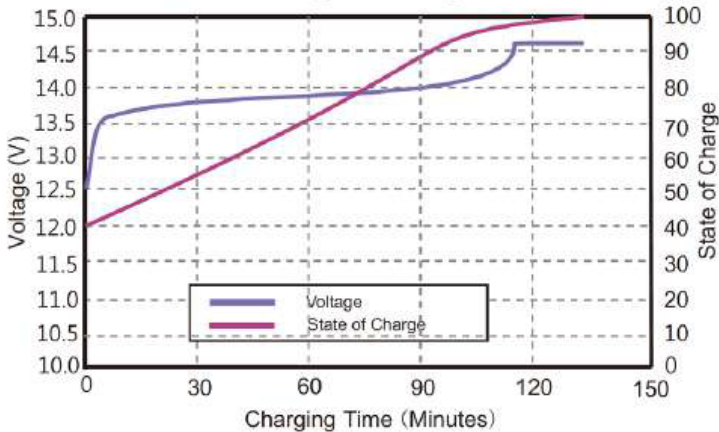

Different DoD Discharge Cycle Life @1C

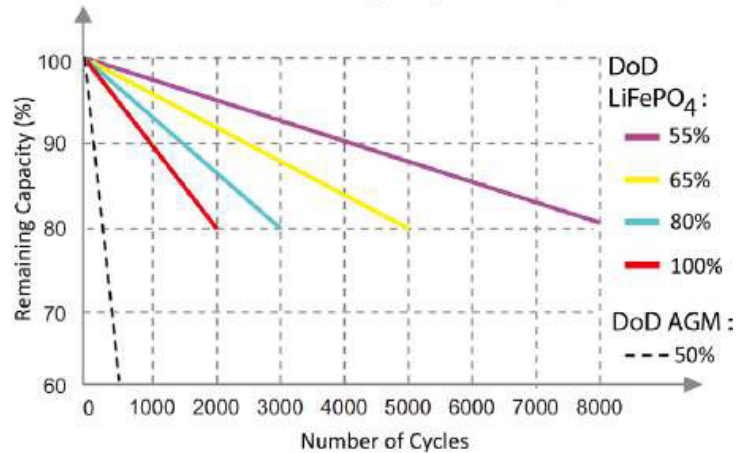

BVD GmbH
Am Leitzelbach 29
74889 Sinsheim

Telefon: 07261-94832-10
E-Mail: bvd@bvd24.de

BVD
Batterie Vertrieb Deutschland

please visit www.bvd24.de